



ASSEMBLY & INSTALLATION GUIDE

C4 Series Shelving

Fits:

Full Sized Low Roof Vans



Contents

ASSEMBLY INSTRUCTIONS	3
1 PREPARATION	3
2 ASSEMBLY FASTENER KIT	4
3 INSTALL FASTENER KIT	4
4 SHELF ASSEMBLY	5
INSTALLATION INSTRUCTONS	6
1 FASTENING BRACKETS TO END PANELS	6
2 MARKING HOLES FOR PLUS NUTS	7
3 INSTALLING PLUS NUTS	8
4 FASTENING SHELF UNIT TO THE WALL	10
5 FASTENING SHELF UNIT TO THE FLOOR	12
6 INSTALLING CENTER SUPPORT	14

Required Items

- 2 People (To Lift Shelf Unit)
- 3/8" Drill Bit
- 3/8" Nut Driver Bit
- 1/2" Drill Bit w/ Drill Collar (Set at 1/2")
- 1/2" Nut Driver Bit
- 9/16" Wrench
- 1" Hole Saw
- Plus Nut Tool or Plus Nut Gun (5/16")
- Marker
- Cordless Drill
- Cordless Impact Driver
- Tape Measure
- Large Square

ASSEMBLY INSTRUCTIONS

1 PREPARATION

Unpack components and compare to the Bill of Materials. Ensure that all of the parts are present.

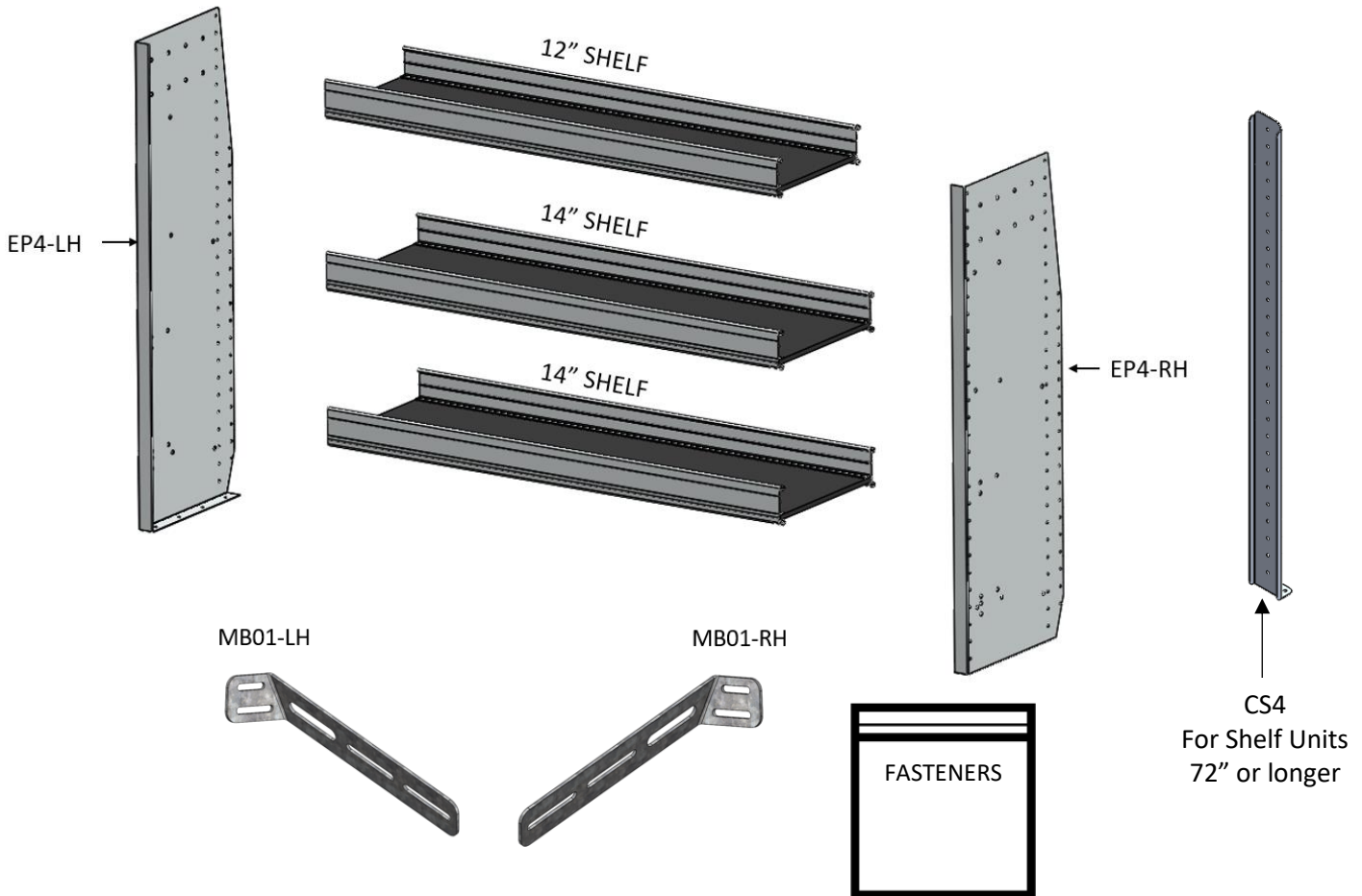









BILL OF MATERIALS

Part Number	Description	Quantity
EP4-LH	SFO Aluminum LH End Panel 45" x 16"	1
EP4-RH	SFO Aluminum LH End Panel 45" x 16"	1
12" Shelf	Shelf Tray Assembly, 12"	1
14" Shelf	Shelf Tray Assembly, 14"	2
MB01-LH	Shelf Mounting Bracket, LH	1
MB01-RH	Shelf Mounting Bracket, RH	1
CS4	LR Centre Support (For Shelf Units 72" or longer)	1
	Assembly Fastener Kit	1
	Install Fastener Kit	1

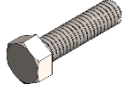
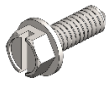
2 ASSEMBLY FASTENER KIT

Quantity	Description	Image	Purpose
32	Hex Washer Head Screw #14 x 1"		Fastening Shelf Trays to the End Panels

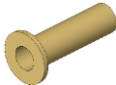
3 INSTALL FASTENER KIT

Quantity	Description	Image	Purpose
4	Hex Bolt 5/16-18 x 3/4		Fastening the Shelf Mounting Brackets to the End Panels
4	Flat Washer 5/16		
4	Serrated Nut 5/16-18		
4	Hex Bolt 5/16-18 x 1-1/4		Fastening the Shelf Assembly to the structure of the vehicle
8	Hex Washer Head Screw #14 x 3/4		
4	Lock Washer 5/16		
4	Flat Washer 5/16		
6	1/4" Nylon Spacer		
4	Serrated Nut 5/16-18		
4	Plus Nut 5/16		
6	Hex Washer Head Screw #14 x 3/4		Installing Centre Support (For Shelf Units 72" or Longer)
2	1/4" Nylon Spacer		

4 SHELF ASSEMBLY

- Position shelf trays on a work bench. Fasten the End Panels to the Shelf Trays using the hardware provided.
- Make sure the bench is clean and smooth to minimize scratches.

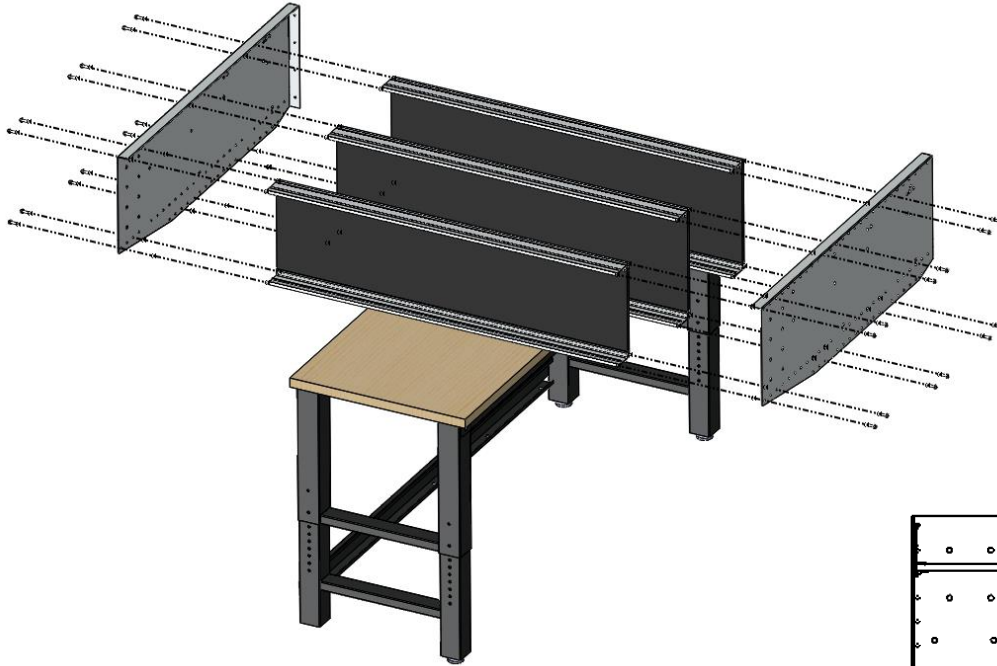

- Set shelf heights as desired – refer to table below for minimum wheel well clearance.

VEHICLE	MINIMUM CLEARANCE (OVER WHEEL WELL)
Mercedes Benz Sprinter	13"
Ford Transit	11.5"
Ram Promaster	17"
GMC Savana	12"

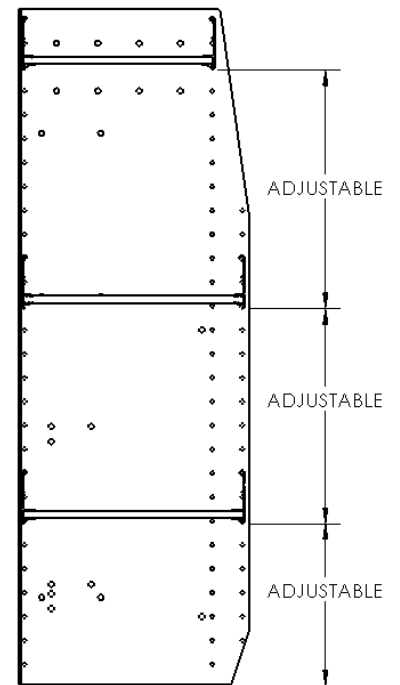

Tools Used:
Cordless Impact Driver
3/8" Nut Driver Bit

Hardware Used:
24 x Hex Washer Head Screw #14 X 1"

INSTALLATION INSTRUCTIONS

1 FASTENING BRACKETS TO END PANELS

1. Lift assembled shelf unit into vehicle and place it in the desired location.
2. Place the mounting brackets so that they align with the horizontal rim of the vehicle as shown.
3. Make 2 marks in the slots of the mounting bracket onto the end panel of the shelf unit.
4. Use a 3/8" drill bit to drill out the holes for mounting the mounting brackets onto the end panels.
5. Fasten the mounting brackets onto the end panels.

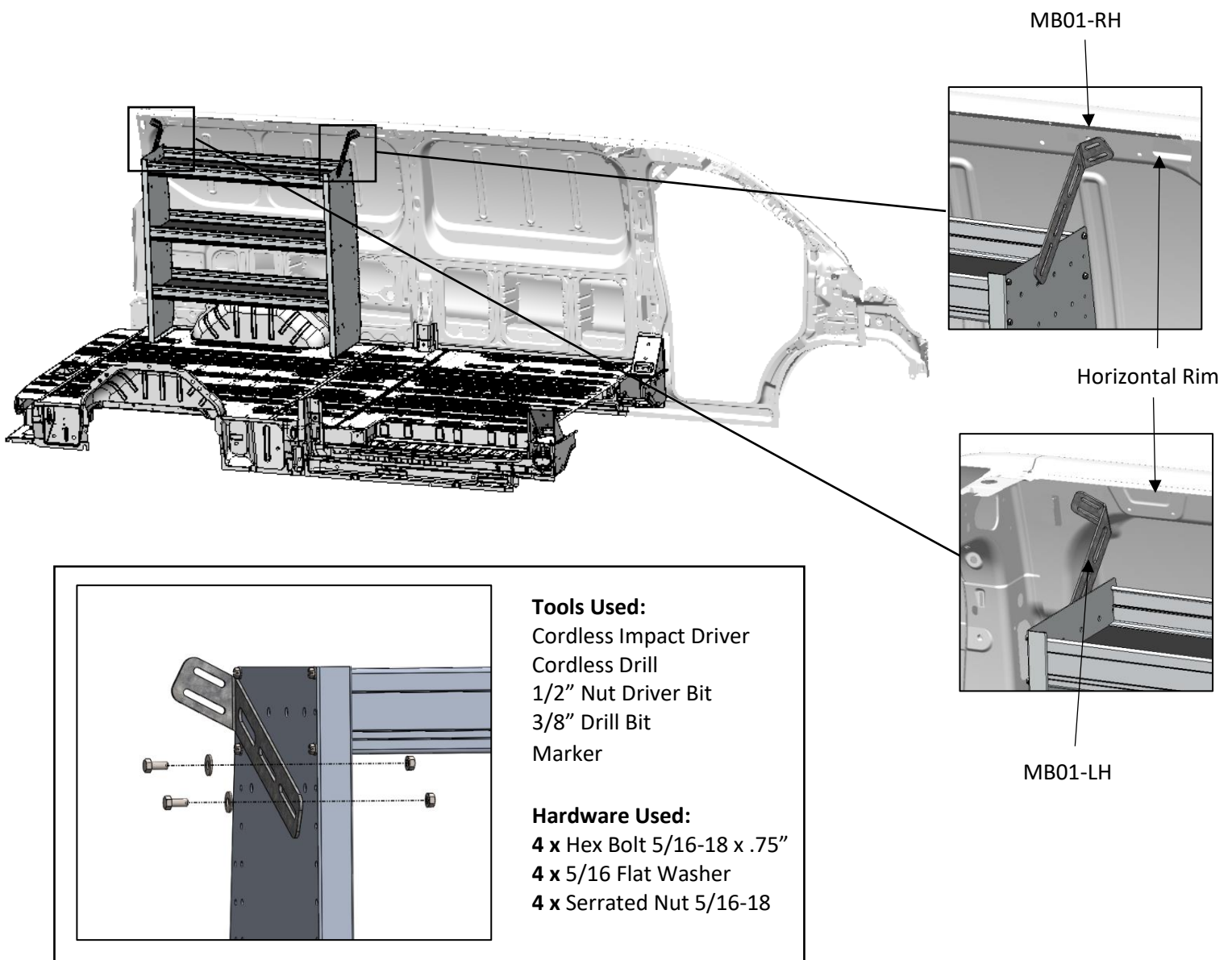

2 MARKING HOLES FOR PLUS NUTS

Mark Plus Nut Locations

Once the mounting brackets are secured to the end panels, marks can be made for installing Plus Nuts onto the vehicle. (See page 11 for vehicles with Wall Kits)

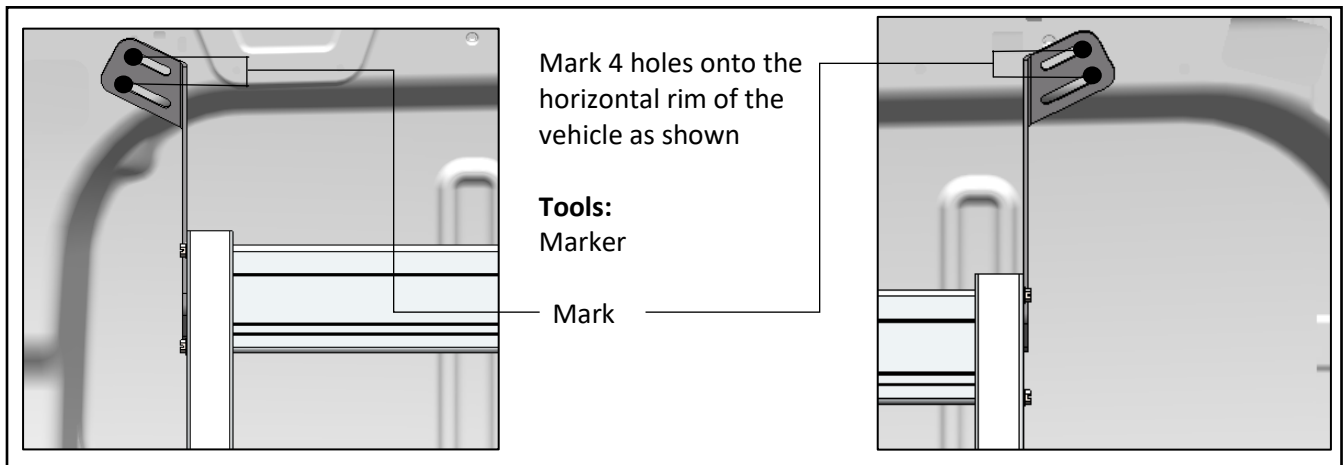
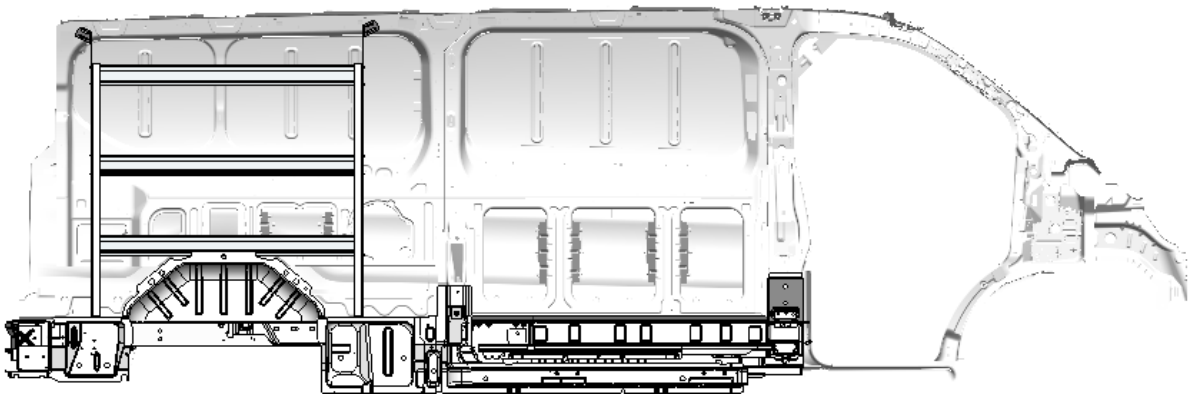

3 INSTALLING PLUS NUTS

1. Lift shelf unit so that it is out of the way.
2. Drill holes using a 1/2" drill bit with a collar to stop drill at 1/2" depth.



WARNING: Check for wiring or gas tanks BEFORE drilling into floors, pillars, headliners, or walls.

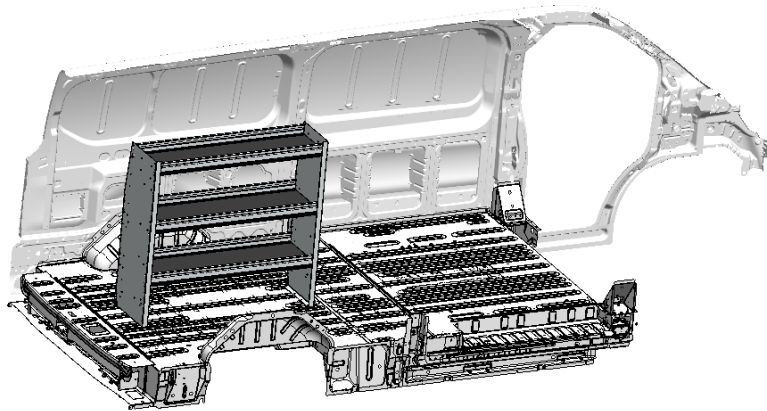

Using a 1/2" drill bit with a 1/2" Drill Collar, drill out all of the marks from the previous step. Install Plus Nuts into drilled holes. Only use Plus Nuts in places where Bolts and Nuts cannot be used.

Tools:

Cordless Drill
1/2" Drill Bit with Drill Collar (Set to 1/2" Depth)

Hardware:

4 x 5/16" Plus Nuts

Plus Nuts

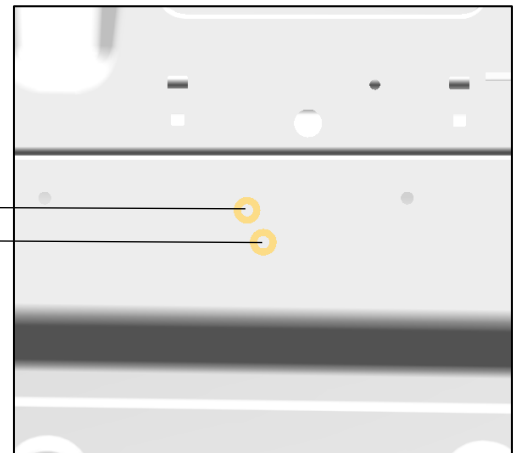

(A) Using Plus Nut Gun: (If available- otherwise see B below)

- Place 2 drops of air tool oil into the air fitting regularly.
- Ensure that there is anti-seize on the Plus Nut Gun threads at all times.
- Thread a Plus Nut onto the threads of the gun, then place bolt and Plus Nut through pre-drilled hole.
- Pull trigger of Plus Nut Gun to compress Plus Nut into the material until the noise changes on the gun.
- Reverse direction on gun to unscrew Bolt from the Plus Nut.

FORWARD

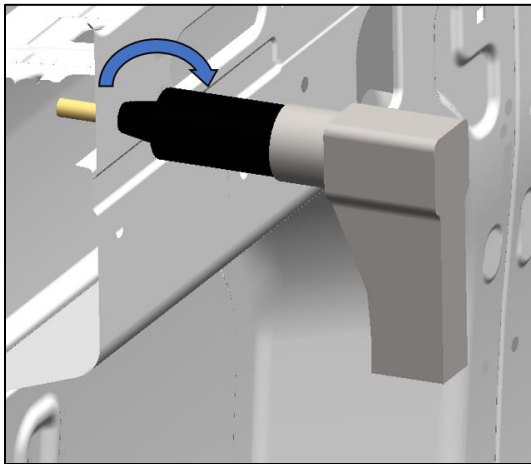

REVERSE

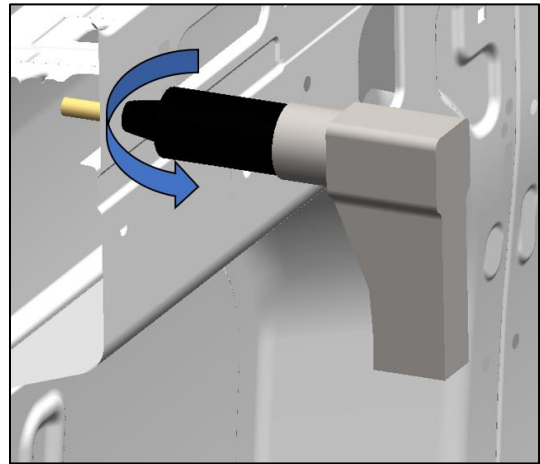

(B) Using Plus Nut Tool:

STEP 1

Assemble the Plus Nut Tool as shown.

Tools:

9/16" Wrench

Hardware:

Plus Nut Tool

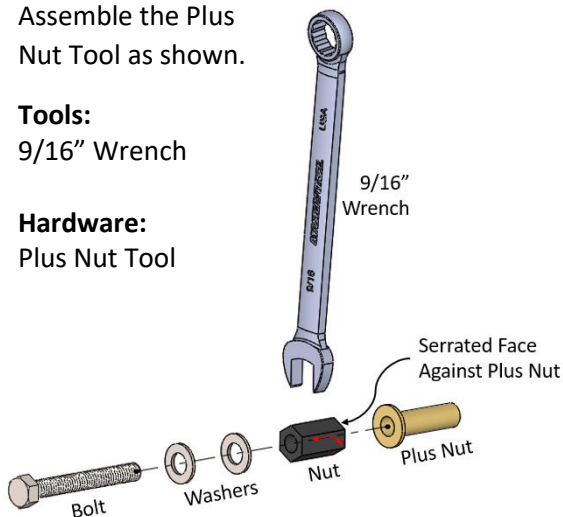

STEP 2

Fasten Plus Nut to vehicle:

- Insert Plus Nut into hole.
- Hold Nut with wrench.
- Tighten bolt until Plus Nut clamps the vehicle body metal tightly.

Tools:

Cordless Impact Driver
1/2" Nut Driver Bit
9/16" Wrench



Hardware:

4 x 5/16" Plus Nuts
Plus Nut Tool

4 FASTENING SHELF UNIT TO THE WALL

Without Wall Kit

Lift the assembled shelf unit back into place ensuring that the slots in the mounting brackets line up with the Plus Nuts in the wall.

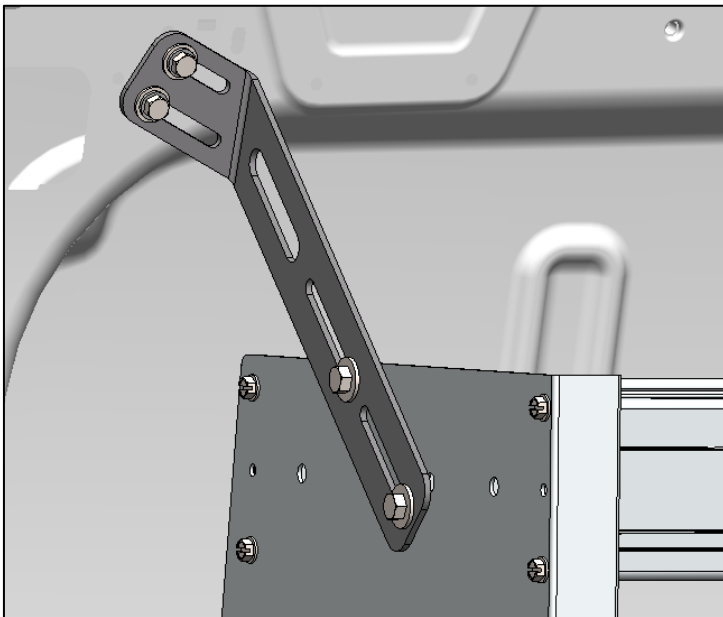
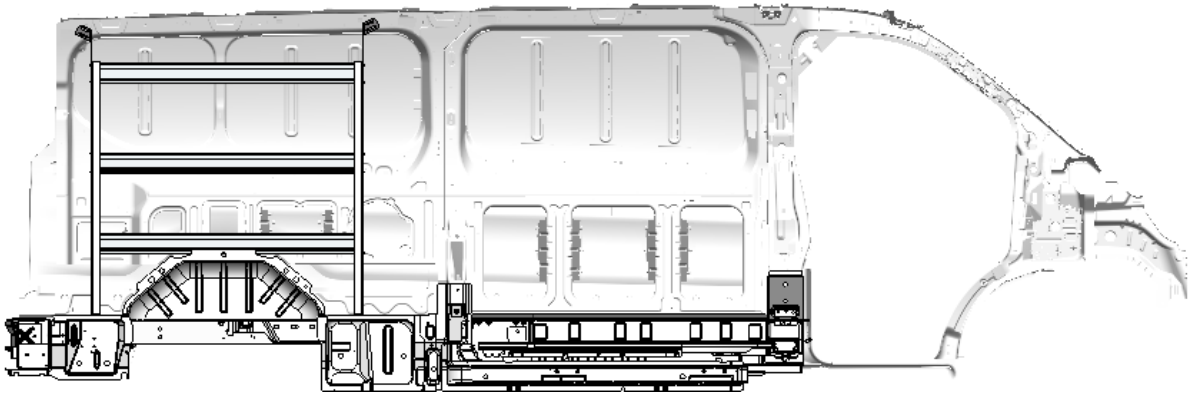

Fasten the Shelf Unit to the wall.

Tools Used:

Cordless Impact Driver
3/8" Nut Driver Bit

Hardware Used:

4 x 5/16-18 x 1-1/4" Hex Bolt
4 x 5/16 Flat Washer
4 x 5/16 Lock Washer
4 x 5/16 Plus Nut

With Wall Kit

1. Make 4 marks using the slots of the mounting brackets onto the wall kit.
2. Use a 1" hole saw to carefully cut out holes in the wall kit at the desired fastener location (in the locations where plus nuts were installed).
3. Use a 1/2" drill with a collar set to a 1/2" depth to drill out the holes.
4. Install the Plus Nuts into the holes. (See page 9)
5. Fasten the Shelf Unit to the vehicle.

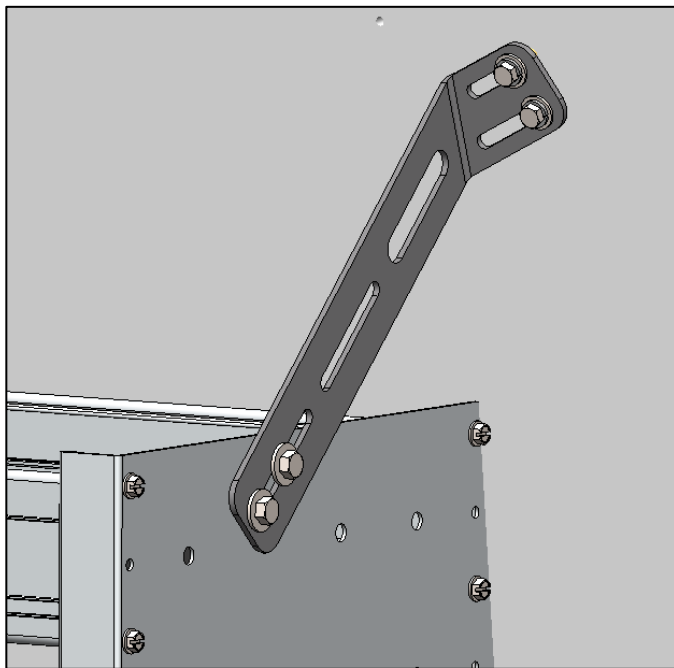
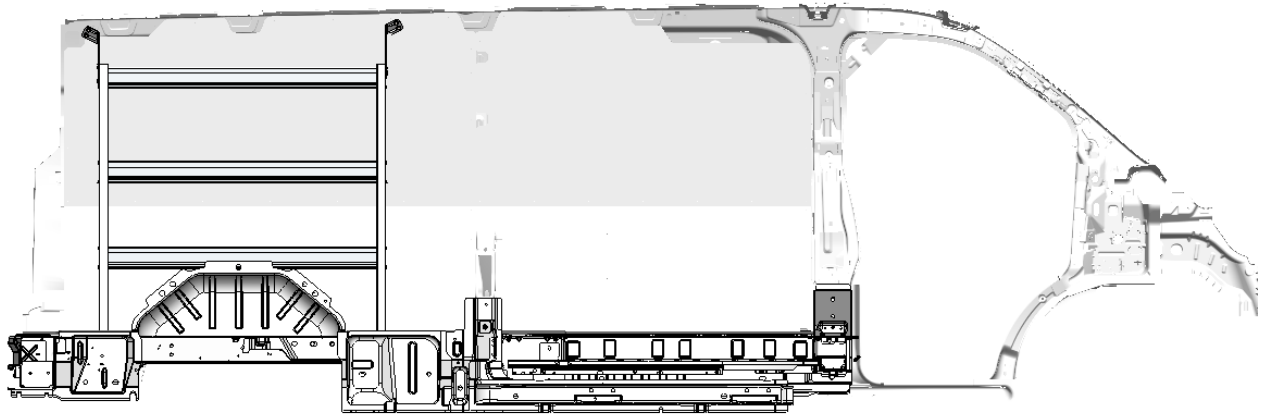

Fasten the Shelf Unit to the wall.

Tools Used:

Cordless Impact Driver
Cordless Drill
1" Hole Saw
1/2" Drill Bit with Drill Collar (Set to 1/2" Depth)
1/2" Nut Driver Bit

Hardware Used:

4 x 5/16-18 x 1-1/4" Hex Bolt
4 x 5/16 Flat Washer
4 x 5/16 Lock Washer
4 x 5/16 Plus Nut

5 FASTENING SHELF UNIT TO THE FLOOR

With Floor Kit

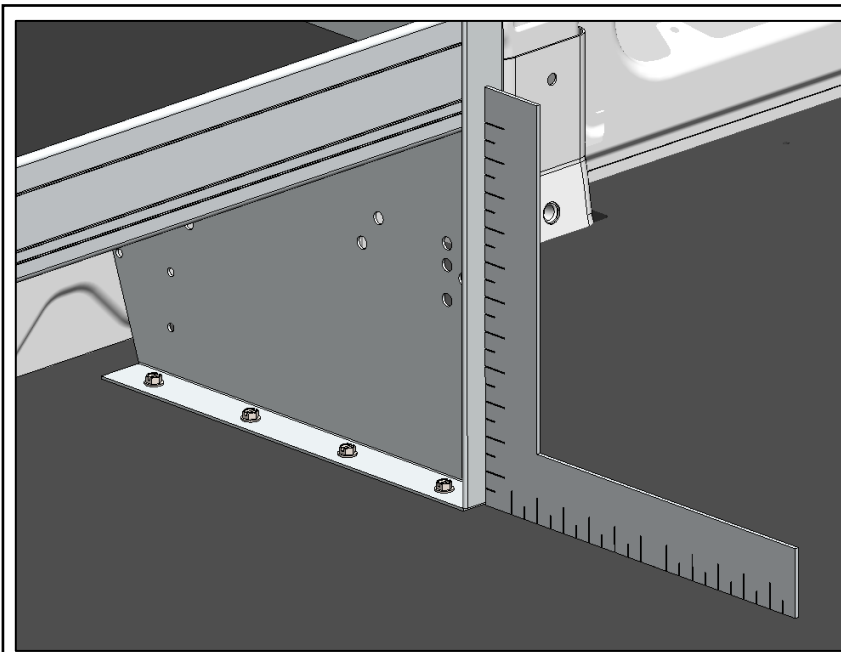
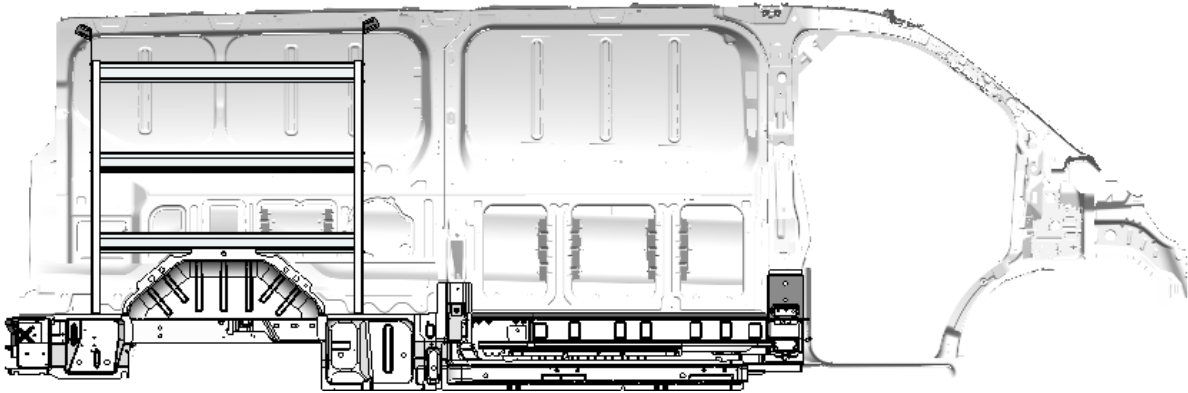

Fasten the Shelf Unit to the subfloor using square to position front 90° to the floor.

Tools Used:

Cordless Impact Driver
3/8" Nut Driver Bit
Large Square

Hardware Used:

8 x Hex Washer Head Screw #14 x 3/4"

Without Floor Kit

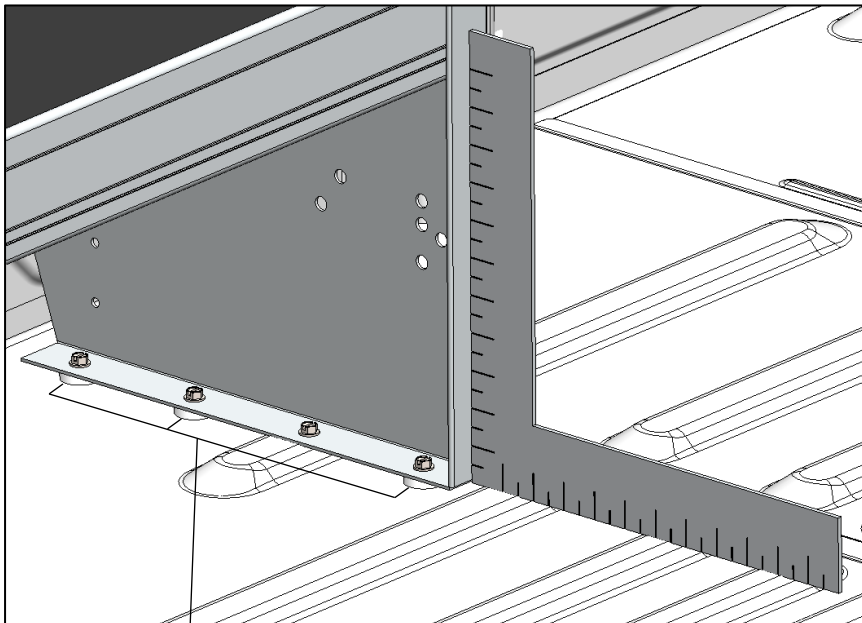
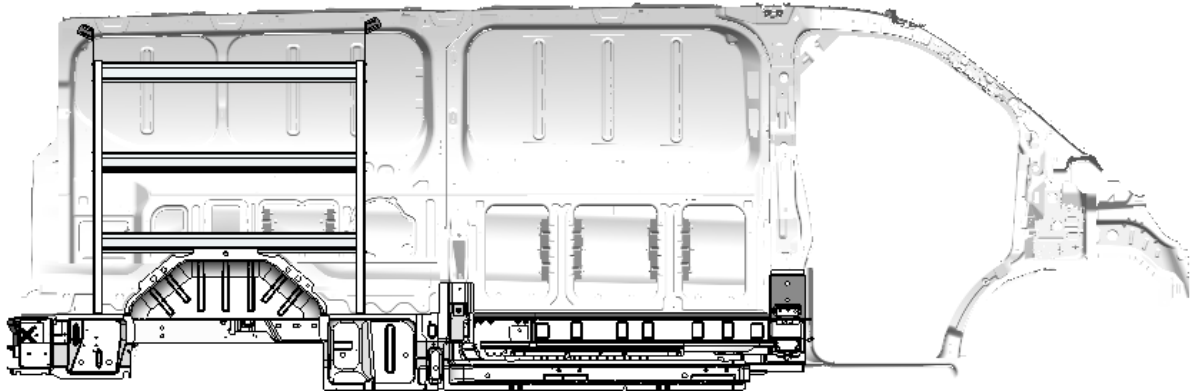

1/4 Nylon Spacers

Fasten the Shelf Unit to the floor using square to position front 90° to the floor. Use 1/4 Nylon Spacers where necessary.

Tools Used:

Cordless Impact Driver
3/8" Nut Driver Bit
Large Square

Hardware Used:

8 x Hex Washer Head Screw #14 x 3/4"
1/4 Nylon Spacer

6 INSTALLING CENTER SUPPORT

For Shelving Units 72" or longer, a Center Support will need to be installed.

With Floor Kit

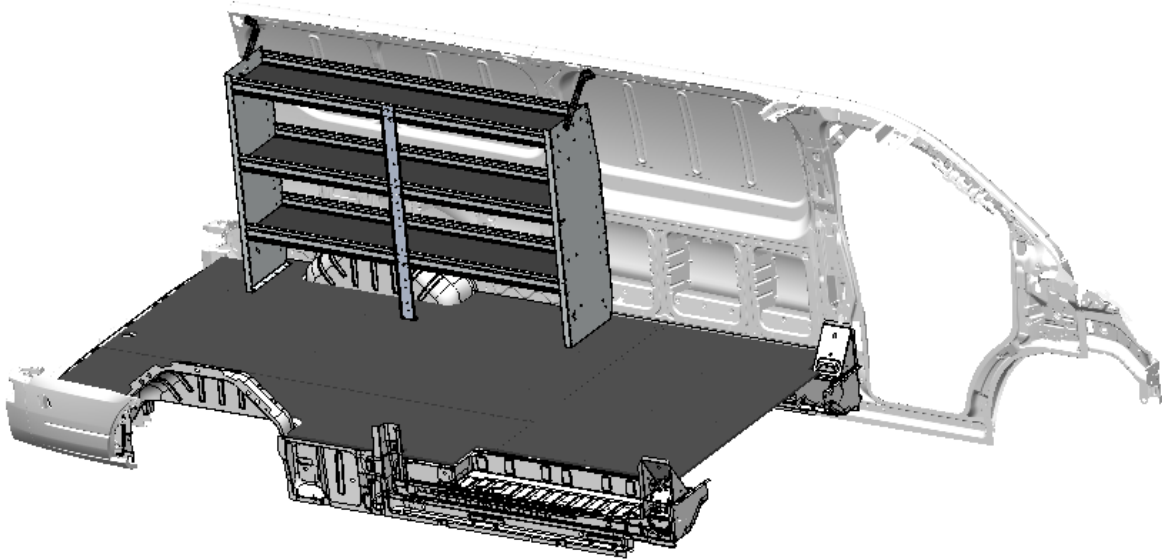

- Measure and mark the center of the Shelving Unit.
- Place the Center Support so that it is centered on the Shelving Unit using square to locate it perpendicular to the floor.
- Fasten Center Support to Shelving Unit.
- Fasten Center Support to Subfloor.

Tools Used:

Cordless Impact Driver
3/8" Nut Driver Bit
Marker
Tape Measure
Large Square

Hardware Used:

5 x Hex Washer Head Screw #14 x 3/4"

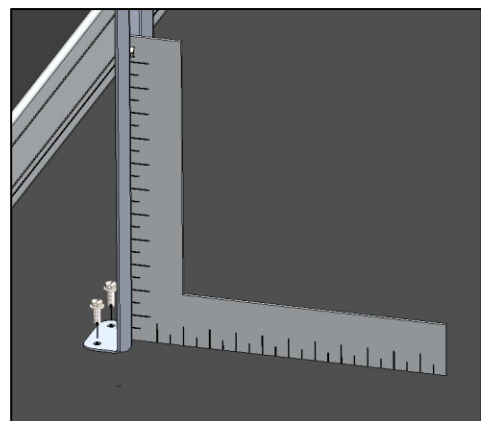
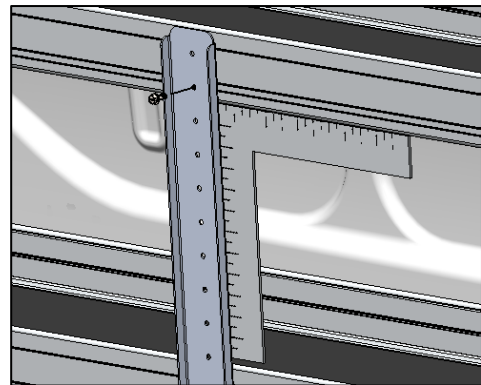

Without Floor Kit

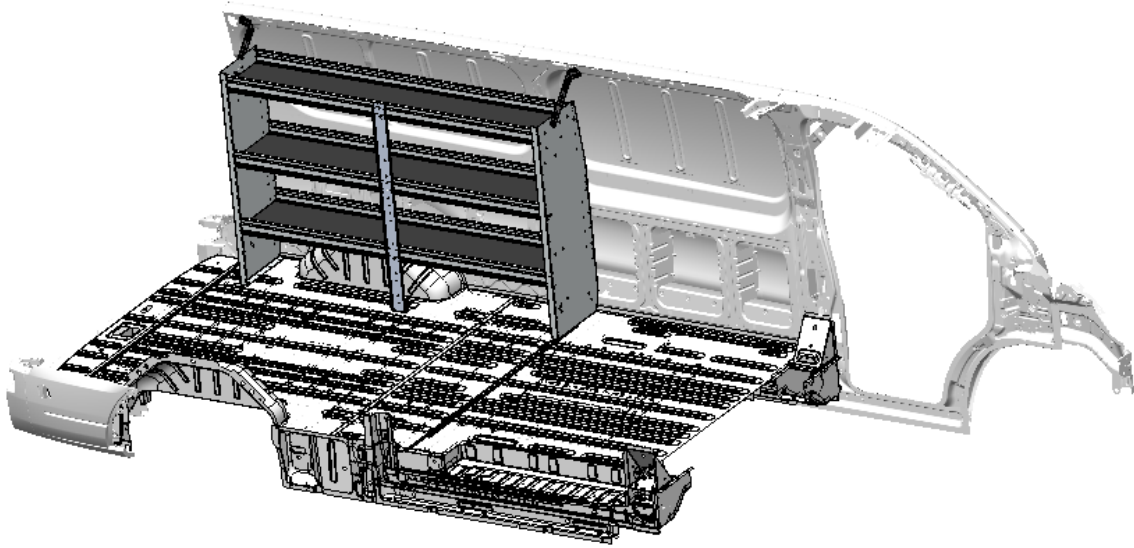

- Measure and mark the center of the Shelving Unit.
- Place the Center Support so that it is centered on the Shelving Unit using square to locate it perpendicular to the floor.
- Fasten Center Support to Shelving Unit.
- Fasten Center Support to floor. Use 1/4" Nylon Spacers where necessary.

Tools Used:

Cordless Impact Driver
3/8" Nut Driver Bit
Marker
Tape Measure
Large Square

Hardware Used:

5 x Hex Washer Head Screw #14 x 3/4"
2 x 1/4" Nylon Spacer

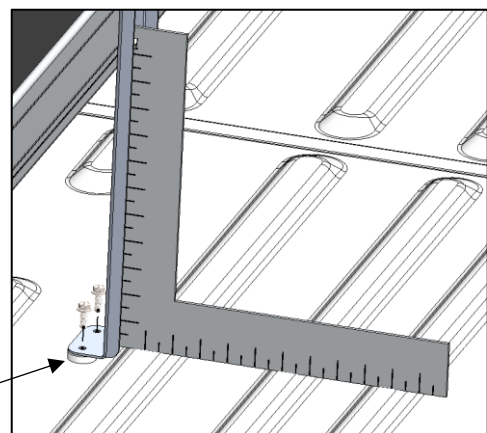
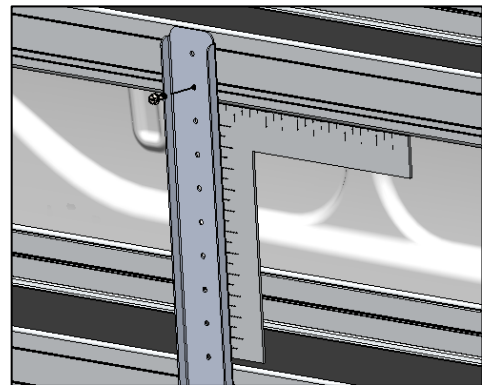

1/4" Nylon Spacer